

LIGHTNIN®

The Leader in Mixing Technology

SSV Mixers

The clear leader for cleanability, versatility and performance.

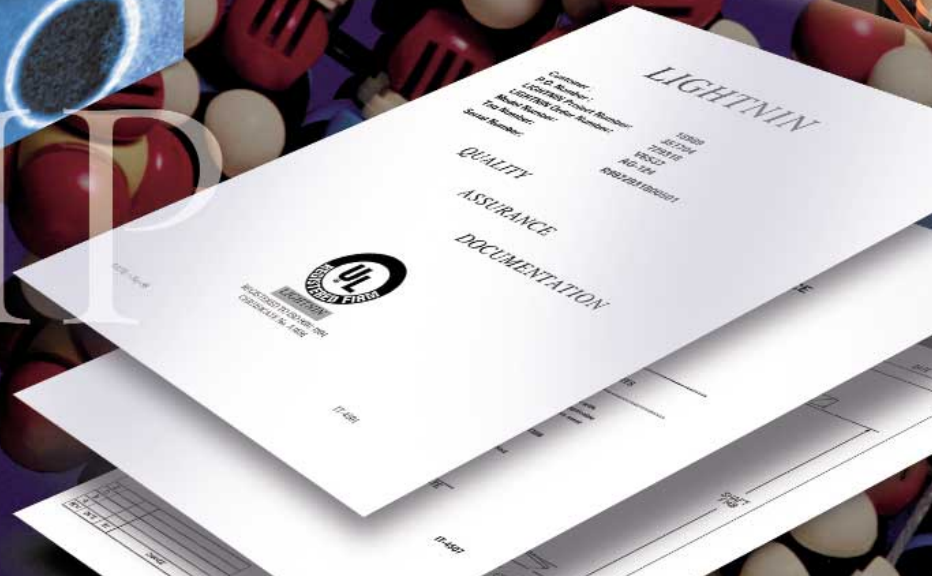

LIGHTNIN's family of SanStar™ Stainless Sanitary Vertical (SSV) mixers is designed specifically to meet the most stringent requirements for cGMP facilities, and to provide a comprehensive array of mixer solutions for the biotechnology and pharmaceutical industries. Suitable for buffer and media preparation, fermenters, bioreactors, product recovery and bulk pharmaceutical processing, these dry-running mixers offer a proven record of superior, dependable performance and clean operation.

- All stainless steel exterior for clean, aseptic environments.
- Modular construction for ease of service, repair and retrofit.
- Minimum footprint for vessels up to 20,000 liters in a vertical, in-line design for closed tank applications.
- Standard designs from 1/4 to 2 HP, with output speeds from 100 to 290 rpm.
- Custom selections available per job for higher power or alternate speeds.
- Wide range of seals available, all with food-grade faces and elastomers:
 - single dry-running with or without sanitary purge gland
 - double dry-running or condensate lubricated
- Mixers mount on standard sanitary tri-clamps to minimize head space requirements; 150# ANSI mounting flanges also available.
- Stainless steel washdown and inverter duty electric motors for maximum flexibility and cleanliness.
- Variety of low-shear, high-efficiency impeller configurations available to meet a full spectrum of process requirements.
- Full clean-in-place, sterilize-in-place (CIP/SIP) features.
- Designed to comply with ASME Bioprocess Equipment Specification.
- Comes with LIGHTNIN's 100% process guarantee.



Sanitary motor, end bell and conduit box for washdown, pressure washing and steam cleaning.

Six standard speeds for a wider choice of operating points.

Polished stainless steel housing for sanitary service.

Large diameter bearings provide rigid shaft support.

Wetted in-tank parts polished to 20 micro inch Ra or better finish, with electropolish. Optional 10 micro inch Ra finish with electropolish available.

Tri-clamp housing connections for ease of installation and maintenance.

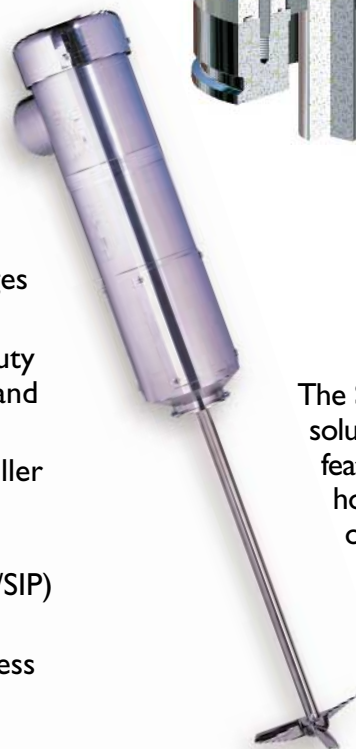

The SSV line also includes a solution for smaller tanks, featuring 3" tri-clamp, fractional horsepower and a full range of validated impellers.

Proven seal designs for today's demanding applications

LIGHTNIN's mechanical seals are designed specifically for the biotechnology, pharmaceutical and food processing marketplace, and can be configured to operate dry or wet for the utmost in performance, application flexibility and economy.



Single Dry-Running Design

- Self-lubricating food-grade carbon on Durchrome runs completely dry without cooling.
- Flexible rotor design compensates for shaft misalignment.
- Contacting dry-running single seal design handles eccentric run-out levels up to 0.125" Full Indicator Movement (FIM).
- Double O-ring mounted stator prevents distortion.

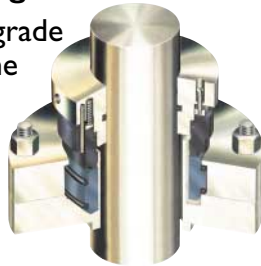

Double Dry-Running Design

- Minimizes product contamination from the barrier fluid.
- Can operate with dry steam or steam condensate barrier fluid.
- Requires no cooling.
- Pressure reversal capabilities for greater seal integrity under off-design operation
- Sanitary design features for improved cleanability.
- Features self-lubricating faces, utilizing carbon vs. peramic materials.

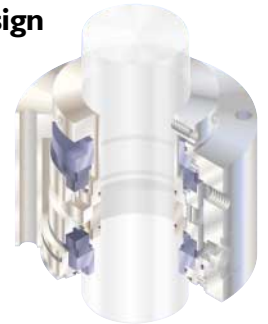

Single Dry-Running with Sanitary Gland

- Optional sanitary purge gland allows steam cleaning and sterilizing of the seal's interior while mounted on the equipment.
- Debris well, inlet and outlet ports are self-draining.
- O-ring seats are relieved for ease of CIP/SIP.
- All product contact surfaces polished and electropolished.

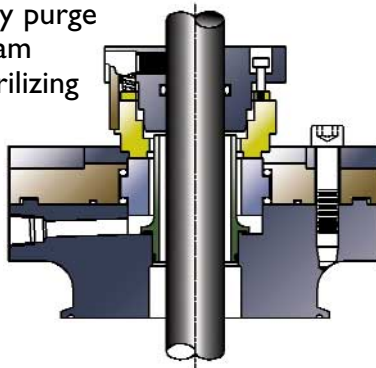

Double Lubricated Design

- A zero emissions seal - no product contamination.
- Cartridge design - easy to install and maintain.
- Utilizes carbon vs. silicon carbide face materials
- Self-draining design

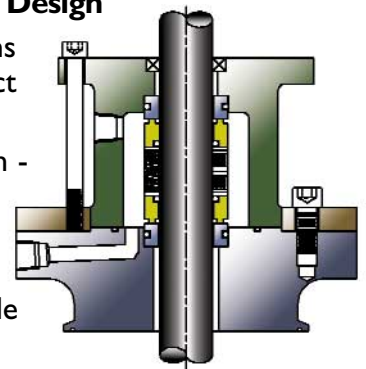

QAD for cGMP requirements, as standard

To demonstrate that FDA-mandated Good Manufacturing Practices (cGMP) guidelines have been met, you receive full Quality Assurance Documentation (QAD) as standard when you purchase a LIGHTNIN SSV mixer.

Specifications

Wetted Parts

- Patented low-shear hydrofoil impeller.
 - A510 (fabricated version of A310).
 - A310 for optional cast construction.
- 316/316L stainless steel shaft and impeller.
- 20 micro inch Ra with electropolish surface finish (optional 10 micro inch Ra with electropolish).

Drive Assembly

- Sealed cycloidal speed reducer.
- L-10 Bearing life exceeds 50,000 hours.
- 1.75 service factor.
- Food-grade lubricant.
- 316L stainless steel housing, output shaft and hardware.

Motors

- Washdown and Inverter duty TEFC, 208-230/460v, 3-Phase, 60 Hz, 300 Series stainless steel exterior.
- AC Variable Frequency Drives (VFD) available.
- Local readout tachometer option.

Pedestal and Mounting Flanges

- 4" or 6" Tri-clamp® sanitary connection; optional sizes and 150# ANSI flanges available.
- 316L stainless steel construction, 32 micro inch Ra exterior finish.
- Solid 316L stainless steel flanges.

Custom Options

- High alloy impeller and shaft.
- Explosion-proof motor (painted only).
- Alternative impellers including props, Rushton turbines, and A315, A320 or A340 high solidity hydrofoils.
- Extended power and speed range.

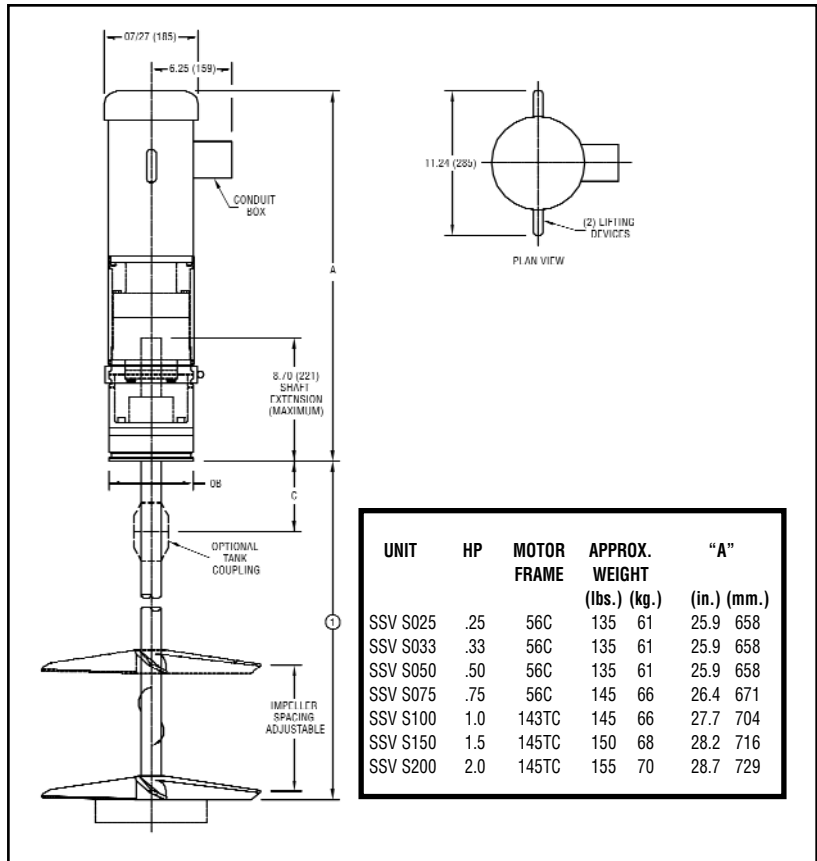

Call the LIGHTNIN experts

For more information about the LIGHTNIN SSV Series or to discuss your application, contact your local LIGHTNIN Sales Representative. Or visit our website at www.lightninemixers.com. Or call 1-888-MIX-BEST (U.S. and Canada), or 1(585) 527-1623 (worldwide).

LIGHTNIN

*When it comes to mixing
We never stop*